

TA-DMDF



7-16 DIN Male to 7-16 DIN Female Low-PIM Adapter

Product Classification

Product Type Adapter

General Specifications

Body Style Straight

Inner Contact Plating Silver

Interface 7-16 DIN Male

Interface 2 7-16 DIN Female

Outer Contact Plating Trimetal

Pressurizable No

Dimensions

Length 38.85 mm | 1.53 in

Diameter 34.6 mm | 1.362 in

Outline Drawing

TA-DMDF

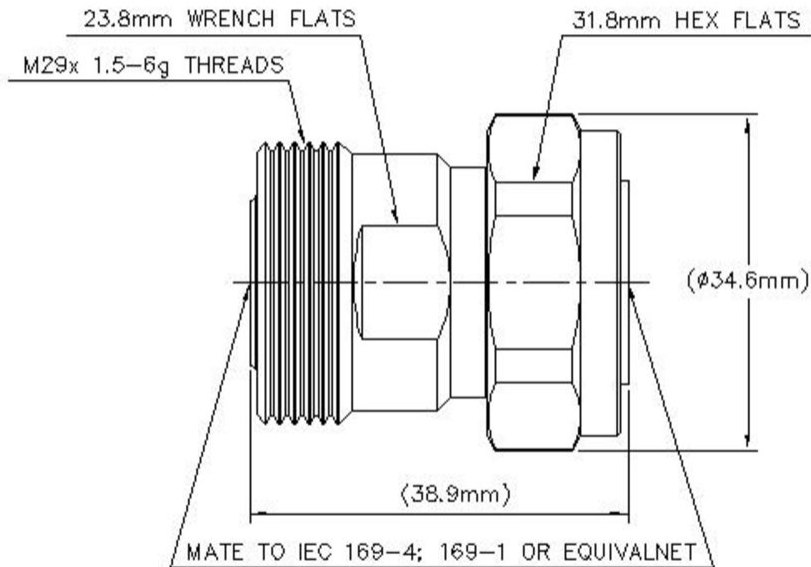

Electrical Specifications

3rd Order IMD at Frequency	-163 dBc @ 1800 MHz
3rd Order IMD Test Method	Two +43 dBm carriers
Attenuation, Ambient Temperature	20 °C 68 °F
Average Power at Frequency	1,300.0 W @ 900 MHz
Connector Impedance	50 ohm
dc Test Voltage	4000 V
Inner Contact Resistance, maximum	0.4 mOhm
Insulation Resistance, minimum	10000 MOhm
Operating Frequency Band	0 – 6000 MHz
Outer Contact Resistance, maximum	1.5 mOhm
Peak Power, maximum	28.8 kW

TA-DMDF

RF Operating Voltage, maximum (vrms) 1200 V

VSWR/Return Loss

Frequency Band	VSWR	Return Loss (dB)
0–3000 MHz	1.05	34
3000–6000 MHz	1.14	24

Mechanical Specifications

Coupling Nut Proof Torque	50 N-m 442.537 in lb
Coupling Nut Proof Torque Method	IEC 61169-4:9.3.6
Coupling Nut Retention Force	800 N 179.847 lbf
Coupling Nut Retention Force Method	IEC 61169-16:9.3.11
Insertion Force	200 N 44.962 lbf
Insertion Force Method	IEC 61169-4:15.2.4
Interface Durability	500 cycles
Interface Durability Method	IEC 61169-4:9.5
Mechanical Shock Test Method	IEC 60068-2-27

Environmental Specifications

Operating Temperature	-55 °C to +85 °C (-67 °F to +185 °F)
Storage Temperature	-65 °C to +125 °C (-85 °F to +257 °F)
Average Power, Ambient Temperature	40 °C 104 °F
Average Power, Inner Conductor Temperature	100 °C 212 °F
Climatic Sequence Test Method	IEC 60068-1
Corrosion Test Method	IEC 60068-2-11
Thermal Shock Test Method	IEC 60068-2-14
Vibration Test Method	IEC 60068-2-6

Packaging and Weights

Weight, net 124.48 g | 0.274 lb

Regulatory Compliance/Certifications

Agency	Classification
CHINA-ROHS	Below maximum concentration value

TA-DMDF

ISO 9001:2015

Designed, manufactured and/or distributed under this quality management system

REACH-SVHC

Compliant as per SVHC revision on www.commscope.com/ProductCompliance

ROHS

Compliant

