

L4TNM-PSA

Type N Male Positive Stop™ for 1/2 in AL4RPV-50, LDF4-50A, HL4RPV-50 cable



- This product is part of the CommScope Wired for Wireless® Solution

Product Classification

Product Type	Wireless and radiating connector
Product Brand	HELIAX® Positive Stop™
Ordering Note	CommScope® standard product (Global)

General Specifications

Body Style	Straight
Cable Family	AL4-50
Harmonized System (HS) Code	854420 (Coaxial cable and other coaxial electric conductors)
Inner Contact Attachment Method	Captivated
Inner Contact Plating	Silver
Interface	N Male
Mounting Angle	Straight
Outer Contact Attachment Method	Ring-flare
Outer Contact Plating	Trimetal

Dimensions

Length	3.02 in 76.708 mm
Diameter	0.88 in 22.352 mm
Nominal Size	1/2 in

Outline Drawing

L4TNM-PSA

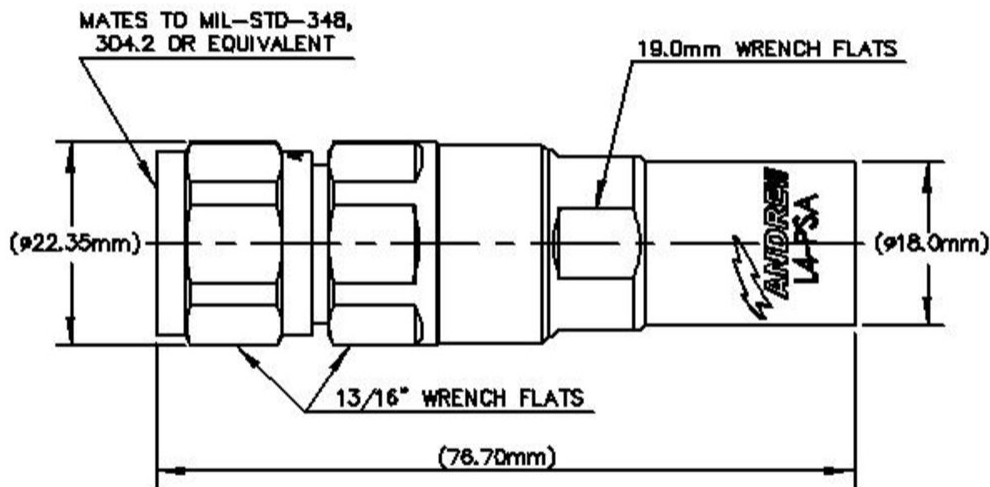

Electrical Specifications

3rd Order IMD at Frequency	-116 dBm @ 910 MHz
3rd Order IMD Test Method	Two +43 dBm carriers
Insertion Loss, typical	0.05 dB
Average Power at Frequency	0.6 kW @ 900 MHz
Cable Impedance	50 ohm
Connector Impedance	50 ohm
dc Test Voltage	2000 V
Inner Contact Resistance, maximum	2 mOhm
Insulation Resistance, minimum	5000 MOhm
Operating Frequency Band	0 – 8800 MHz
Outer Contact Resistance, maximum	0.3 mOhm

L4TNM-PSA

Peak Power, maximum	10 kW
RF Operating Voltage, maximum (vrms)	707 V
Shielding Effectiveness	-130 dB

VSWR/Return Loss

Frequency Band	VSWR	Return Loss (dB)
45–1000 MHz	1.03	39
1010–2200 MHz	1.03	37
2210–3000 MHz	1.05	33
3010–4000 MHz	1.1	27
4010–6000 MHz	1.26	19
6010–8000 MHz	1.33	17

Mechanical Specifications

Attachment Durability	25 cycles
Connector Retention Tensile Force	200 lbf 889.644 N
Connector Retention Torque	48 in lb 5.423 N-m
Coupling Nut Proof Torque	40 in lb 4.519 N-m
Coupling Nut Retention Force	100 lbf 444.822 N
Coupling Nut Retention Force Method	MIL-C-39012C-3.25, 4.6.22
Insertion Force	15 lbf 66.723 N
Insertion Force Method	MIL-C-39012C-3.12, 4.6.9
Interface Durability	500 cycles
Interface Durability Method	IEC 61169-16:9.5
Mechanical Shock Test Method	MIL-STD-202, Method 213, Test Condition I

Environmental Specifications

Operating Temperature	-55 °C to +85 °C (-67 °F to +185 °F)
Storage Temperature	-55 °C to +85 °C (-67 °F to +185 °F)
Corrosion Test Method	MIL-STD-1344A, Method 1001.1, Test Condition A
Immersion Depth	1 m
Immersion Test Mating	Unmated
Immersion Test Method	IEC 60529:2001, IP68
Moisture Resistance Test Method	MIL-STD-202F, Method 106F

L4TNM-PSA

Thermal Shock Test Method	MIL-STD-202F, Method 107G, Test Condition A-1, Low Temperature -55 °C
Vibration Test Method	IEC 60068-2-6
Water Jetting Test Mating	Unmated
Water Jetting Test Method	IEC 60529:2001, IP66

Packaging and Weights

Weight, net 94.71 g | 0.209 lb

Regulatory Compliance/Certifications

Agency	Classification
CHINA-ROHS	Above maximum concentration value
ISO 9001:2015	Designed, manufactured and/or distributed under this quality management system
REACH-SVHC	Compliant as per SVHC revision on www.commscope.com/ProductCompliance
ROHS	Compliant/Exempted



* Footnotes

Immersion Depth	Immersion at specified depth for 24 hours
Insertion Loss, typical	$0.05\sqrt{\text{freq}}$ (GHz) (not applicable for elliptical waveguide)