

AL6DF-PSA



7-16 DIN Female Positive Stop™ for 1-1/4 in AVA6-50 cable

Product Classification

Product Type	Wireless and radiating connector
Product Brand	HELIAX® Positive Stop™
Ordering Note	CommScope® standard product in Europe, the Middle East, and Africa

General Specifications

Body Style	Straight
Cable Family	AVA6-50
Inner Contact Attachment Method	Captivated
Inner Contact Plating	Silver
Interface	7-16 DIN Female
Mounting Angle	Straight
Outer Contact Attachment Method	Ring-flare
Outer Contact Plating	Trimetal
Pressurizable	No

Dimensions

Length	2.6 in 66.04 mm
Diameter	2.02 in 51.308 mm
Nominal Size	1-1/4 in

Outline Drawing

AL6DF-PSA

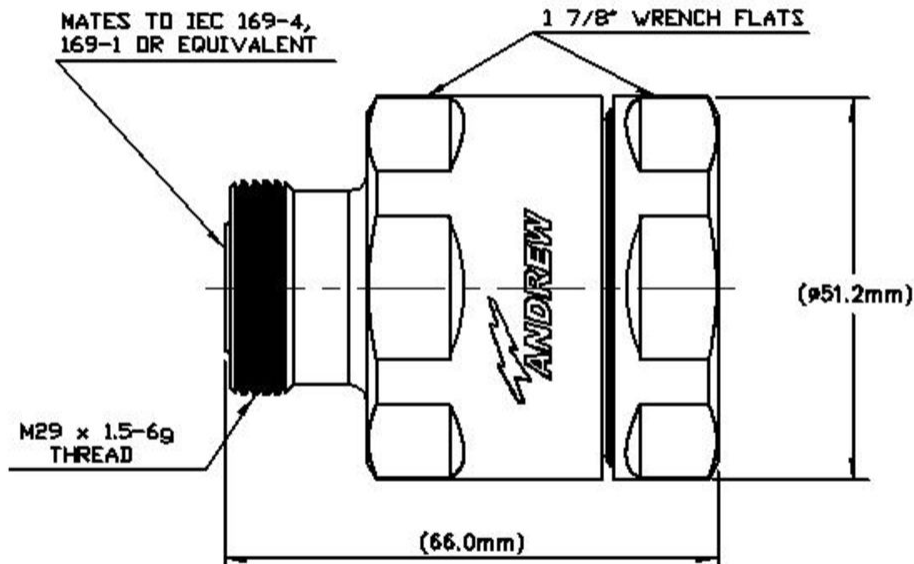

Electrical Specifications

3rd Order IMD at Frequency	-116 dBm @ 1800 MHz
3rd Order IMD Test Method	Two +43 dBm carriers
Insertion Loss, typical	0.05 dB
Attenuation, Ambient Temperature	20 °C 68 °F
Average Power at Frequency	3.0 kW @ 900 MHz
Cable Impedance	50 ohm
Connector Impedance	50 ohm
dc Test Voltage	4000 V
Inner Contact Resistance, maximum	0.8 mOhm
Insulation Resistance, minimum	5000 MOhm
Operating Frequency Band	0 – 3700 MHz

AL6DF-PSA

Outer Contact Resistance, maximum	1.5 mOhm
Peak Power, maximum	40 kW
RF Operating Voltage, maximum (vrms)	1415 V
Shielding Effectiveness	-130 dB

VSWR/Return Loss

Frequency Band	VSWR	Return Loss (dB)
45–1000 MHz	1.04	35
1010–2200 MHz	1.06	32
2210–2700 MHz	1.07	29.42
2710–3300 MHz	1.11	26

Mechanical Specifications

Attachment Durability	25 cycles
Connector Retention Tensile Force	400 lbf 1,779.288 N
Connector Retention Torque	96 in lb 10.847 N-m
Insertion Force	45 lbf 200.17 N
Insertion Force Method	IEC 61169-1:15.2.4
Interface Durability	50 cycles
Interface Durability Method	IEC 61169-16:9.5
Mechanical Shock Test Method	MIL-STD-202F, Method 213B, Test Condition C

Environmental Specifications

Operating Temperature	-55 °C to +85 °C (-67 °F to +185 °F)
Storage Temperature	-55 °C to +85 °C (-67 °F to +185 °F)
Average Power, Ambient Temperature	40 °C 104 °F
Corrosion Test Method	MIL-STD-1344A, Method 1001.1, Test Condition A
Immersion Depth	1 m
Immersion Test Mating	Unmated
Immersion Test Method	IEC 60529:2001, IP68
Moisture Resistance Test Method	MIL-STD-202F, Method 106F
Thermal Shock Test Method	MIL-STD-202F, Method 107G, Test Condition A-1, Low Temperature -55 °C
Vibration Test Method	MIL-STD-202F, Method 204D, Test Condition B

AL6DF-PSA

Water Jetting Test Mating	Unmated
Water Jetting Test Method	IEC 60529:2001, IP66

Packaging and Weights

Weight, net	362 g 0.798 lb
--------------------	------------------

Regulatory Compliance/Certifications

Agency	Classification
CHINA-ROHS	Below maximum concentration value
ISO 9001:2015	Designed, manufactured and/or distributed under this quality management system
REACH-SVHC	Compliant as per SVHC revision on www.commscope.com/ProductCompliance
ROHS	Compliant



* Footnotes

Immersion Depth	Immersion at specified depth for 24 hours
Insertion Loss, typical	$0.05\sqrt{\text{freq}}$ (GHz) (not applicable for elliptical waveguide)