

Ultra Compact 450 MHz Tx/Rx Combiner System 3-channel 2 HU 19" single tray

DESCRIPTION

- An integrated single tray combining solution housing a 3-channel hybrid Tx hybrid combiner, duplex filter, active 3-channel Rx multicouplers and preselector.
- Minimal 19" rack space required - only 2 HU.
- Built-in power supply 115/230 VAC.
- Compatible with digital 6.25 kHz channel spacing.
- Single Tx isolators fitted as standard.
- Please specify all Tx/Rx frequencies when ordering.

- Please Note:
Power cable is not included, must be ordered separately, see Accessories.



SPECIFICATIONS

Electrical	
Model	PRO-HDAR450-3 ...
Frequency	l : 340 - 400 MHz h : 406 - 470 MHz
Max. Input Power	50 W (per channel)
Max. Tx-Tx Spacing, Δ Tx	2 MHz
Min. Tx-Rx Spacing	5 MHz
Isolation Rx on Frequency Tx	Tx - Tx spacing < 0.5 MHz : > 85 dB Tx - Tx spacing > 0.5 MHz : > 65 dB
Insertion Loss Tx Path	< 7.0 dB
Impedance	50 Ω
Ant-Tx Isolation	> 40 dB @ 25 °C
Gain	Rx PATH : 1 dB ±1 dB (factory set)
Isolation Rx-Rx	> 20 dB
Isolation Tx-Tx	> 70 dB
VSWR	≤ 1.5:1
Isolation Tx on Frequency Rx	Rx - Rx spacing < 0.5 MHz : > 85 dB Rx - Rx spacing > 0.5 MHz : > 65 dB
LNA Noise Figure	< 3.5 dB
No. of channels	3
Power Supply	
Voltage	85 - 264 VAC
Frequency	47 - 63 Hz
AC current (typ.)	0.35 A / 115 VAC 0.25 A / 230 VAC

Mechanical	
Connection(s)	N(f)
Dimensions	19" x 2 HU 483 x 89.9 mm 19.02 x 3.54 in. - see drawing for depth of tray
Weight	Approx. 9.6 kg / 21.16 lb.
Environmental	
Operating Temperature Range	-30 °C to +60 °C

BLOCK DIAGRAM

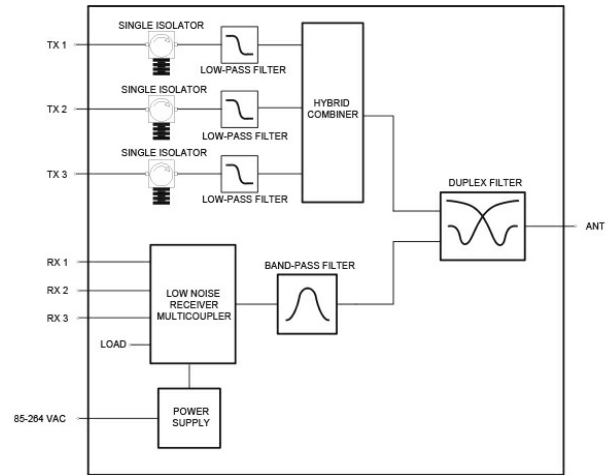

ORDERING DESIGNATIONS

CONTACT FOR SYSTEM-SPECIFIC PRODUCT NO.

Use the guide below to make the name of the PRO-HDAR450-3 you would like to buy. Remember to buy the Power Adaptor separately if needed.

Model	Combiner Freq. Band	Rx Frequencies	Duplex filter Bandwidth (BW) and Tx/Rx Spacing	Hybrid Tx frequencies
PRO-HDAR450-3	Low : 340 - 400 MHz = L High : 406 - 470 MHz = H	406 - 440 MHz = L 440 - 470 MHz = H	2-5/7-2 * 2-7/9-2 2-9/13-2 2-13/16-2 * Max. Low BW: 2 MHz- Tx/Rx spacing: 5 to 7 MHz - Max. High BW: 2 MHz = 2-5/7-2	395 - 410 MHz = 1 405 - 420 MHz = 2 415 - 430 MHz = 3 425 - 440 MHz = 4 435 - 450 MHz = 5 445 - 460 MHz = 6 455 - 470 MHz = 7 465 - 480 MHz = 8
Naming Example				
PRO-HDAR450-3	H	H	/2-5/7-2/	5

Naming Example: PRO-HDAR450-3 HH/2-5/7-2/5

ACCESSORIES

Model	Product No.
Power Cable EU , with Ground	210002646
Power Cable UK , with Ground	210002647
Power Cable US , with Ground	210002648

MOUNTING DETAILS

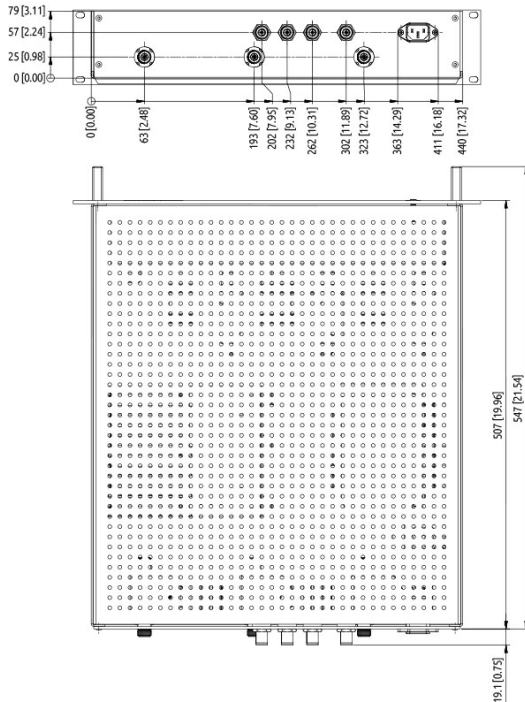

All dimensions are given in mm [in.]

EU AND UK DECLARATION OF CONFORMITY

Hereby Amphenol Procom declare that the product type PRO-HDAR450-3 is in compliance with EU Directive 2014/53/EU and the UK Radio Equipment Regulations 2017 (S.I. 2017 No. 1206).
The full text of the Declaration of Conformity is available at:

<https://amphenolprocom.com/images/shop/catalog/pdf-for-catalogues/Declaration-of-Conformity-PRO-HDAR-2HU.pdf>