

CA-NFSM

Type N Female to SMA Male Adapter

Product Classification

Product Type Adapter

General Specifications

Body Style Straight

Inner Contact Plating Gold

Interface N Female

Interface 2 SMA Male

Mounting Angle Straight

Outer Contact Plating Trimetal

Pressurizable No

Dimensions

Width 16 mm | 0.63 in

Length 29.27 mm | 1.152 in

Diameter 16 mm | 0.63 in

Outline Drawing

CA-NFSM

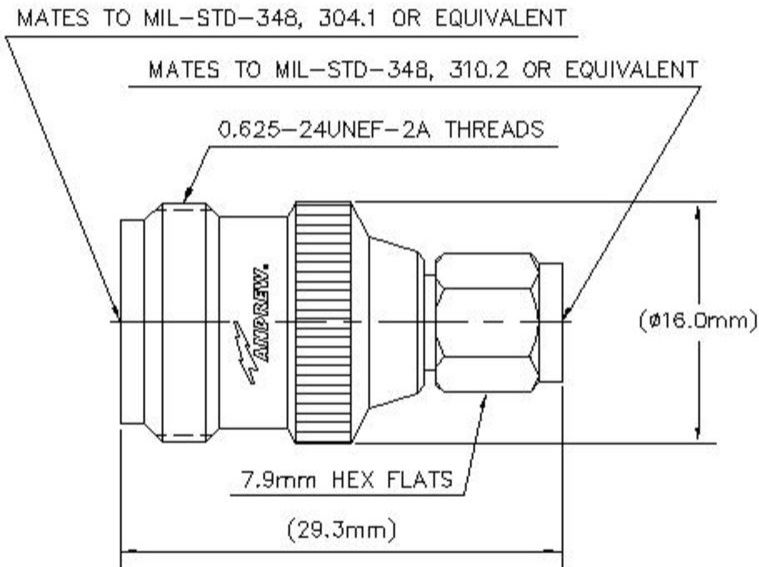

Electrical Specifications

Attenuation, Ambient Temperature	20 °C 68 °F
Average Power at Frequency	100.0 W @ 900 MHz
Connector Impedance	50 ohm
dc Test Voltage	1000 V
Inner Contact Resistance, maximum	3 mOhm
Insulation Resistance, minimum	5000 MOhm
Operating Frequency Band	0 – 6000 MHz
Outer Contact Resistance, maximum	2.5 mOhm
Peak Power, maximum	5 kW
RF Operating Voltage, maximum (vrms)	500 V

CA-NFSM

VSWR/Return Loss

Frequency Band	VSWR	Return Loss (dB)
0–3000 MHz	1.041	33.95
3000–6000 MHz	1.083	28

Mechanical Specifications

Coupling Nut Proof Torque	1.7 N-m 15.046 in lb
Coupling Nut Proof Torque Method	IEC 61169-15:9.3.6
Coupling Nut Retention Force	180 N 40.466 lbf
Coupling Nut Retention Force Method	IEC 61169-15:9.3.11
Insertion Force	28 N 6.295 lbf
Insertion Force Method	IEC 61169-16:9.3.5
Interface Durability	500 cycles
Interface Durability Method	IEC 61169-15:9.5 IEC 61169-16:9.5
Mechanical Shock Test Method	IEC 60068-2-27

Environmental Specifications

Operating Temperature	-55 °C to +85 °C (-67 °F to +185 °F)
Storage Temperature	-65 °C to +125 °C (-85 °F to +257 °F)
Average Power, Ambient Temperature	40 °C 104 °F
Average Power, Inner Conductor Temperature	100 °C 212 °F
Climatic Sequence Test Method	IEC 60068-1
Corrosion Test Method	IEC 60068-2-11
Damp Heat Steady State Test Method	IEC 60068-2-3
Thermal Shock Test Method	IEC 60068-2-14
Vibration Test Method	IEC 60068-2-6

Packaging and Weights

Weight, net	23.8 g 0.052 lb
--------------------	-------------------

Regulatory Compliance/Certifications

Agency	Classification
ISO 9001:2015	Designed, manufactured and/or distributed under this quality management system

CA-NFSM

