

L1TNF-PL



Type N Female Positive Lock for 1/4 in LDF1-50 cable

Product Classification

Product Type	Wireless and radiating connector
Product Brand	HELIAX®

General Specifications

Body Style	Straight
Cable Family	LDF1-50
Inner Contact Attachment Method	Captivated
Inner Contact Plating	Silver
Interface	N Female
Mounting Angle	Straight
Outer Contact Attachment Method	Self-flare
Outer Contact Plating	Trimetal
Pressurizable	No

Dimensions

Height	0.63 in 16.002 mm
Width	0.63 in 16.002 mm
Length	1.84 in 46.736 mm
Diameter	0.63 in 16.002 mm
Nominal Size	1/4 in

Outline Drawing

L1TNF-PL

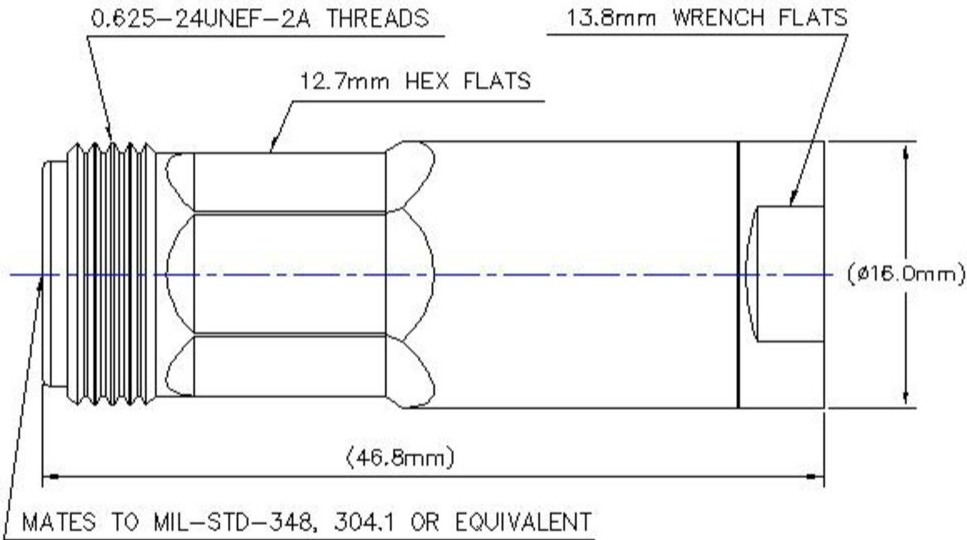

Electrical Specifications

3rd Order IMD at Frequency	-107 dBm @ 910 MHz
3rd Order IMD Test Method	Two +43 dBm carriers
Insertion Loss, typical	0.05 dB
Attenuation, Ambient Temperature	20 °C 68 °F
Average Power at Frequency	0.6 kW @ 900 MHz
Cable Impedance	50 ohm
Connector Impedance	50 ohm
dc Test Voltage	2200 V
Inner Contact Resistance, maximum	1 mOhm
Insulation Resistance, minimum	5000 MOhm
Operating Frequency Band	0 – 12000 MHz

LITNF-PL

Outer Contact Resistance, maximum	0.25 mOhm
Peak Power, maximum	10 kW
RF Operating Voltage, maximum (vrms)	707 V
Shielding Effectiveness	-110 dB

VSWR/Return Loss

Frequency Band	VSWR	Return Loss (dB)
0–960 MHz	1.04	35.6
960–2200 MHz	1.06	31
2200–2700 MHz	1.06	30.8
2700–4000 MHz	1.07	30
4000–6000 MHz	1.13	24.8
6000–8000 MHz	1.28	18.4
8000–10000 MHz	1.3	17.8
10000–12000 MHz	1.31	17.6

Mechanical Specifications

Attachment Durability	25 cycles
Connector Retention Tensile Force	101 lbf 449.27 N
Coupling Nut Proof Torque	15.05 in lb 1.7 N-m
Insertion Force	6.29 lbf 27.979 N
Insertion Force Method	IEC 61169-1:15.2.4
Interface Durability	500 cycles
Interface Durability Method	IEC 61169-16:9.5
Mechanical Shock Test Method	IEC 60068-2-27

Environmental Specifications

Operating Temperature	-55 °C to +85 °C (-67 °F to +185 °F)
Storage Temperature	-65 °C to +125 °C (-85 °F to +257 °F)
Average Power, Ambient Temperature	40 °C 104 °F
Average Power, Inner Conductor Temperature	100 °C 212 °F
Corrosion Test Method	IEC 60068-2-11
Immersion Depth	1 m
Immersion Test Mating	Mated

L1TNF-PL

Immersion Test Method	IEC 60529:2001, IP68
Moisture Resistance Test Method	IEC 60068-2-3
Thermal Shock Test Method	IEC 60068-2-14
Vibration Test Method	IEC 60068-2-6

Packaging and Weights

Weight, net 44.92 g | 0.099 lb

Regulatory Compliance/Certifications

Agency	Classification
CHINA-ROHS	Below maximum concentration value
ISO 9001:2015	Designed, manufactured and/or distributed under this quality management system
REACH-SVHC	Compliant as per SVHC revision on www.commscope.com/ProductCompliance
ROHS	Compliant



* Footnotes

Immersion Depth	Immersion at specified depth for 24 hours
Insertion Loss, typical	$0.05\sqrt{\text{freq}}$ (GHz) (not applicable for elliptical waveguide)