

114EZNF



Type N Female EZfit® for 1-1/4 in FXL1480 and AVA6-50 cable

Product Classification

Product Type	Wireless and radiating connector
Product Brand	EZfit®
Product Series	AVA6-50 AVA6RK-50
Ordering Note	ANDREW® standard product (Global)

General Specifications

Body Style	Straight
Cable Family	AVA6-50 FXL-1480
Inner Contact Attachment Method	Captivated
Inner Contact Plating	Silver
Interface	N Female
Mounting Angle	Straight
Outer Contact Attachment Method	Clamp
Outer Contact Plating	Trimetal
Pressurizable	No

Dimensions

Length	65.79 mm 2.59 in
Diameter	49.02 mm 1.93 in
Nominal Size	1-1/4 in

Outline Drawing

114EZNF

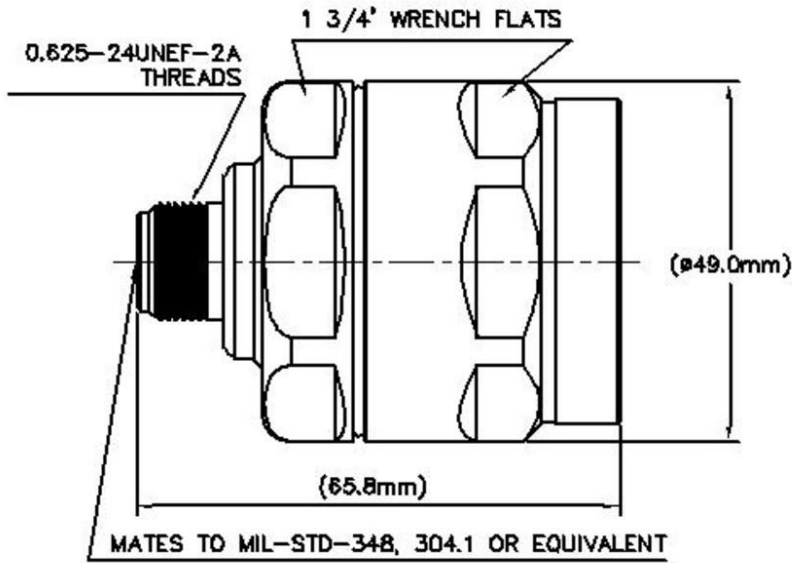

Electrical Specifications

3rd Order IMD at Frequency	-116 dBm @ 1800 MHz
3rd Order IMD Test Method	Two +43 dBm carriers
Insertion Loss Coefficient, typical	0.05
Average Power at Frequency	0.6 kW @ 900 MHz
Cable Impedance	50 ohm
Connector Impedance	50 ohm
dc Test Voltage	2000 V
Inner Contact Resistance, maximum	2 mOhm
Insulation Resistance, minimum	5000 MOhm
Operating Frequency Band	0 – 4000 MHz
Outer Contact Resistance, maximum	0.3 mOhm
Peak Power, maximum	10 kW
RF Operating Voltage, maximum (vrms)	707 V

VSWR/Return Loss

Frequency Band	VSWR	Return Loss (dB)
50-1000 MHz	1.029	36.9
1000-1900 MHz	1.041	33.94

114EZNF

1900–2200 MHz	1.041	33.94
2200–2700 MHz	1.041	33.94
2700–3300 MHz	1.065	30.04

Mechanical Specifications

Attachment Durability	25 cycles
Connector Retention Tensile Force	1,334.47 N 300 lbf
Connector Retention Torque	8.14 N-m 72.001 in lb
Insertion Force	66.72 N 15 lbf
Insertion Force Method	IEC 61169-1:15.2.4
Interface Durability	500 cycles
Interface Durability Method	IEC 61169-4:9.5
Mechanical Shock Test Method	IEC 60068-2-27

Environmental Specifications

Operating Temperature	-40 °C to +85 °C (-40 °F to +185 °F)
Storage Temperature	-55 °C to +85 °C (-67 °F to +185 °F)
Attenuation, Ambient Temperature	20 °C 68 °F
Average Power, Ambient Temperature	40 °C 104 °F
Corrosion Test Method	IEC 60068-2-11, Test Condition Ka
Immersion Depth	1 m
Immersion Test Mating	Mated
Immersion Test Method	IEC 60529:2001, IP68
Moisture Resistance Test Method	IEC 60529, IP68
Vibration Test Method	IEC 60068-2-6
Water Jetting Test Mating	Mated
Water Jetting Test Method	IEC 60529:2001, IP66

Packaging and Weights

Weight, net	284 g 0.626 lb
--------------------	------------------

Regulatory Compliance/Certifications

Agency	Classification
CHINA-ROHS	Below maximum concentration value

114EZNF

ISO 9001:2015	Designed, manufactured and/or distributed under this quality management system
REACH-SVHC	Compliant as per SVHC revision on www.andrew.com/ProductCompliance
ROHS	Compliant
UK-ROHS	Compliant



* Footnotes

Insertion Loss Coefficient, typical 0.05√freq (GHz) (not applicable for elliptical waveguide)

Immersion Depth Immersion at specified depth for 24 hours