

Dual-frequency Mobile Antenna for the 160 and 450 MHz Bands

DESCRIPTION

- > Field-tunable dual-frequency antenna which makes it possible to:
 - operate 160 and 450 MHz transceivers alternately on the same antenna
 - operate two transceivers (160 and 450 MHz) at the same time on one antenna using a diplexer (type DIPX 225/330 – must be ordered separately).
- > Only a single hole has to be drilled instead of two.
- > Car appearance is not destroyed by an “antenna farm”.
- > Ideal for covert services.
- > Stainless steel X-mount with M6-thread whip-fastening system.
- > Simple mounting exclusively with access from the outside.
- > Choice between two connection principles:
 - > X-mount, CX-mount: FME-connection (supplied without cable).
 - > XP4-mount, CXP4-mount: Permanently attached 4 m cable terminated with FME-connector.
 - > XG-Combi mount: FME-connection and GPS (supplied without cable).
 - > XGP4-Combi mount: Permanently attached 4 m cable terminated with FME-connector for whip and 0.15 m RG 178 with MFME for GPS.
- > Easily removable whip for car wash.
- > GPS-antenna for fixed installations.
 - > Full hemispherical coverage.
 - > Built-in high-gain, low-noise amplifier.
 - > Right-Hand Circular Polarization (RHCP).
 - > 2.85 V - 5 V supply voltage (typical 3 V).



ORDERING

Type	Product No.	Description
MHU 3-X	130000770	X-mount (oblong) with FME-system
MHU 3-CX	130000771	CX-mount (circular) with FME-system
MHU 3-XG	Contact for availability	XG-combi mount (oblong) with FME-system and GPS
MHU 3-XP4	130000776	XP4-mount (oblong) with 4 m cable and FME-connector
MHU 3-CXP4	130000772	CXP4-mount (circular) with 4 m cable and FME-connector
MHU 3-XGP4	Contact for availability	XGP4-combi mount (oblong) with 4 m cable, FME-connector and GPS

SPECIFICATIONS

Electrical	
Model	MHU 3-X, MHU 3-CX, MHU 3-XG
Frequency	160 MHz frequency within: 140-170 MHz 450 MHz frequency within: 400-480 MHz
Antenna Type	Dual-frequency mobile antenna
Max. Input Power	100 W
Polarisation	Vertical
Impedance	50 Ω
Bandwidth	160 MHz: 4 MHz @ SWR = 2.0 450 MHz: 24 MHz @ SWR = 2.0
Gain (EIA RS-329-1)	0 - 3 dB

Mechanical	
Materials	Whip: Black-chromed stainless steel and brass Mount: Black-chromed brass Weather- and shockproof plastics Stainless steel
Installation Torque	4 +/- 1 Nm
Colour	Black
Height	56 mm / 2.20 in.
Weight	X-version: Approx. 170 g XP4-version: Approx. 305 g CX-version: Approx. 170 g CXP4-version: Approx. 305 g XG-version: Approx. 185 g XGP4-version: Approx. 325 g

ADDITIONAL DATA

The whip is compatible with all below mounts

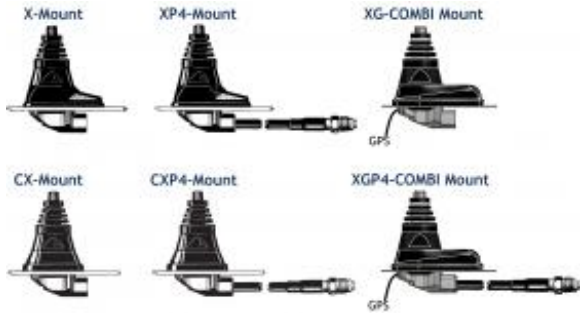

INSTALLATION AND ASSEMBLY INSTRUCTIONS

Please refer to the data sheet of each individual mount to find the installation and assembly instructions.

OPERATION USING A DIPLEXER

In case of operating two transceivers on one antenna at the same time, a diplexer, type DIPX 225/330 is necessary to complete the system. The tasks of the diplexer are to protect the two receiver inputs from being destroyed by the transmitter in the contrary band, and to ensure a low-loss path between the transceiver and the antenna, which is not loaded by the other branch. For further details please see the separate data sheet on the DIPX 225/330. The diplexer fully covers both bands and, consequently, tuning to specific frequencies is not required.

COUPLING DIAGRAM

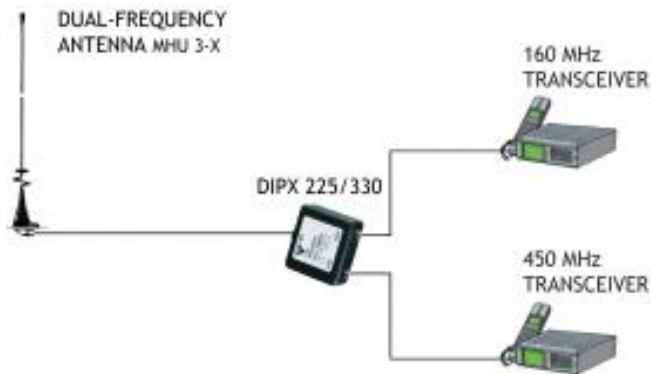

PLEASE NOTE

With this type of combination antenna only certain frequencies from the segments 140 - 170 MHz and 400 - 480 MHz can be covered at the same time. The combination area corresponding to "allowable" frequency pairs is shown in the diagram below. However, taking into account the inherent bandwidth of the antenna the combination area may be increased significantly. The antenna can also be delivered factory tuned. Please consult our price list concerning additional charges for adjustment by cutting.

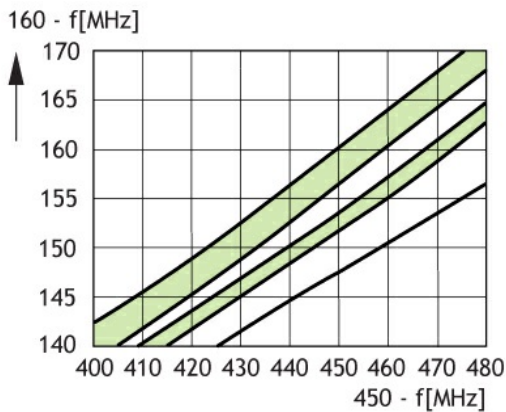

TUNING INFORMATION

The MHU 3-X cannot be tuned to any pair of frequencies in the two bands. Further, the antenna must be equipped with a different kind of adjustment disc depending on the frequency pair in question. The antenna can be used without adjustment disc, with a small adjustment disc or with a large adjustment disc. All adjustment disc types are supplied with the antenna.

Use the diagrams below as follows:

1. Draw a horizontal line through the point on the vertical axis which corresponds to the 160 MHz frequency in question.
2. The drawn horizontal line intersects the shaded area over a certain band of 450 MHz frequencies. If the 450 MHz frequency to be covered is not included in the shaded area, try another diagram (another adjustment disc type). If the 450 MHz frequency is not covered in any of the diagrams, coverage of the frequency pair in question is not possible using this type of antenna. Please note, however, that taking into account the inherent bandwidth of the antenna (± 2 MHz in the 160MHz band and ± 12 MHz in the 450 MHz band) the combination area may be increased considerably.

For the relevant diagram:

3. Read the total length L_1 on the left horizontal axis and cut the whip to this length.
4. Locate the 450 MHz frequency in question on the right horizontal axis and read the corresponding length L_2 from the curves in the shaded area.

WITH NO ADJUSTMENT DISC:

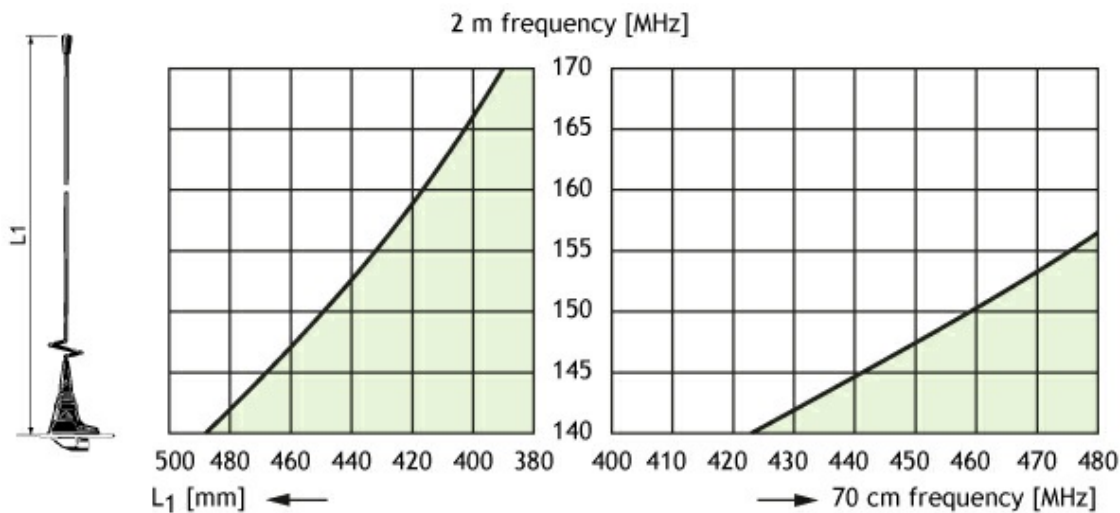

WITH THE SMALL ADJUSTMENT DISC:

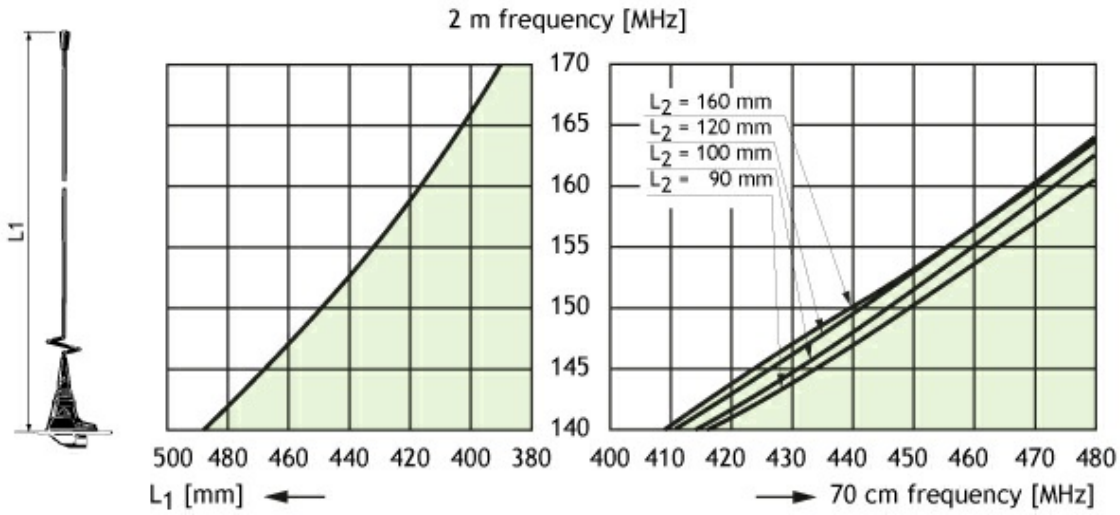

WITH THE LARGE ADJUSTMENT DISC:

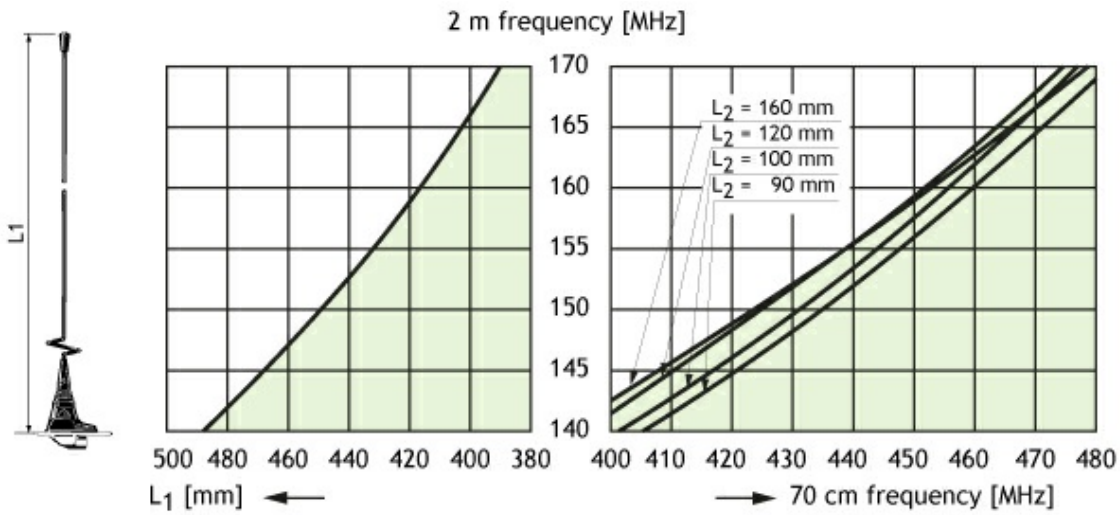

USE AN SWR-METER TO FINE-TUNE THE SETTINGS

