

## ¼ λ Glass fibre Ground-Plane Antenna for the 80 MHz and 160 MHz Bands

### DESCRIPTION

- The radiator is measured from its free end to the bottom of the black insulator, while the radials are measured from their free ends to where they meet the GP-head. The radials must be placed short/long alternately.
- GP 80/160 is a dual-band glass fibre ground-plane antenna of the triple-leg type.
- The antenna is tunable (by cutting) within its main frequency bands: 66...88 MHz/145...175 MHz.
- The cutting diagrams below indicate the length of the radiators and the radials corresponding to specific frequencies within the two bands. It is recommended to use the curves as a guide and fine-tune using an SWR-meter.
- The antenna comprises a brass GP-head, two glass fibre radiators and six glassfiber radials.
- GP 80/160 is made of first-class materials and will endure "wear and tear" for years – no maintenance required.
- LW-SS-1" mounting bracket and GP Adaptor is available as accessories.

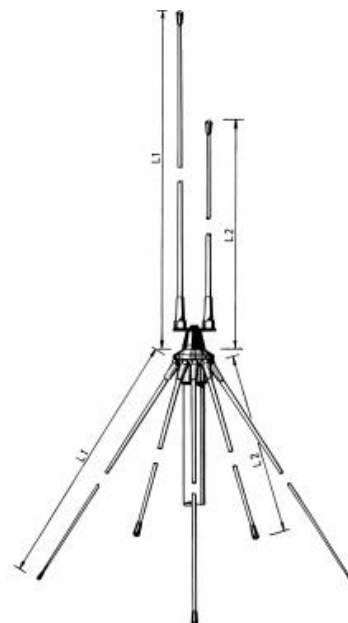

### ORDERING

Type	Product No.
GP 80/160	100000066
GP 80/160/42 mm	100000067
LW-SS-1"	110000394
GP Adaptor	100000679

### SPECIFICATIONS

Electrical	
Model	GP 80/160
Frequency	66-88 MHz / 145-175 MHz
Antenna Type	Dual-band ¼λ full-size ground-plane
Max. Input Power	250 W
Polarisation	Vertical
Pattern Type	Omnidirectional
3 dB Beamwidth, H-Plane	Omnidirectional
Impedance	50 Ω
Gain	0 dBd (2.2 dBi)
Bandwidth	Approx. 5 MHz on both bands

Mechanical	
Connection(s)	N(f)
Materials	Elements : Glass fibre Metal parts : Bright chromed brass
Colour	White (RAL 9003) / Bright chrome
Wind Area	0.05 sq. m / 0.54 sq. ft
Wind Load	63 N (160km/h)
Height	1800 mm / 70.87 in.
Weight	1.5 kg / 3.31 lb
Mounting	38 mm dia. mast tube (42 mm dia. as option, see note)

ADDITIONAL DATA

CUTTING DIAGRAMS

